

NEXIA Series Horizontal Robot Layout (3 Axis Servo)

NEXIA-600S-CYCT

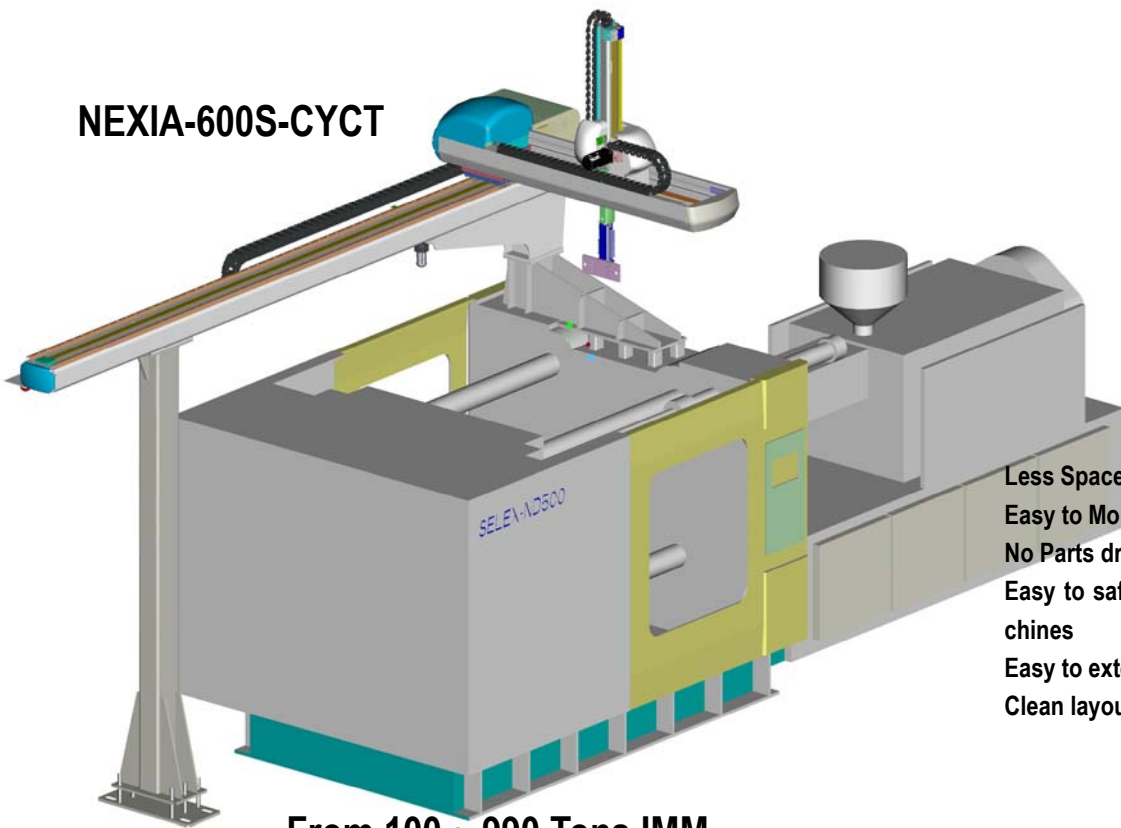

From 100 ~ 990 Tons IMM

Pros

- Less Space between machines required.
- Easy to Mold Change
- No Parts drop on operator side
- Easy to safety guard at the end of molding machines
- Easy to extend traverse Stroke.
- Clean layout

& Cons

- Installation is not simple.
- Long traverse Stroke means more overall cycle
- Rack and Pinion on Traverse Stroke.
- Support beam required at the end of Traverse Stroke.
- More cost for extended and support beam.

NEXIA-2000S-CYCT

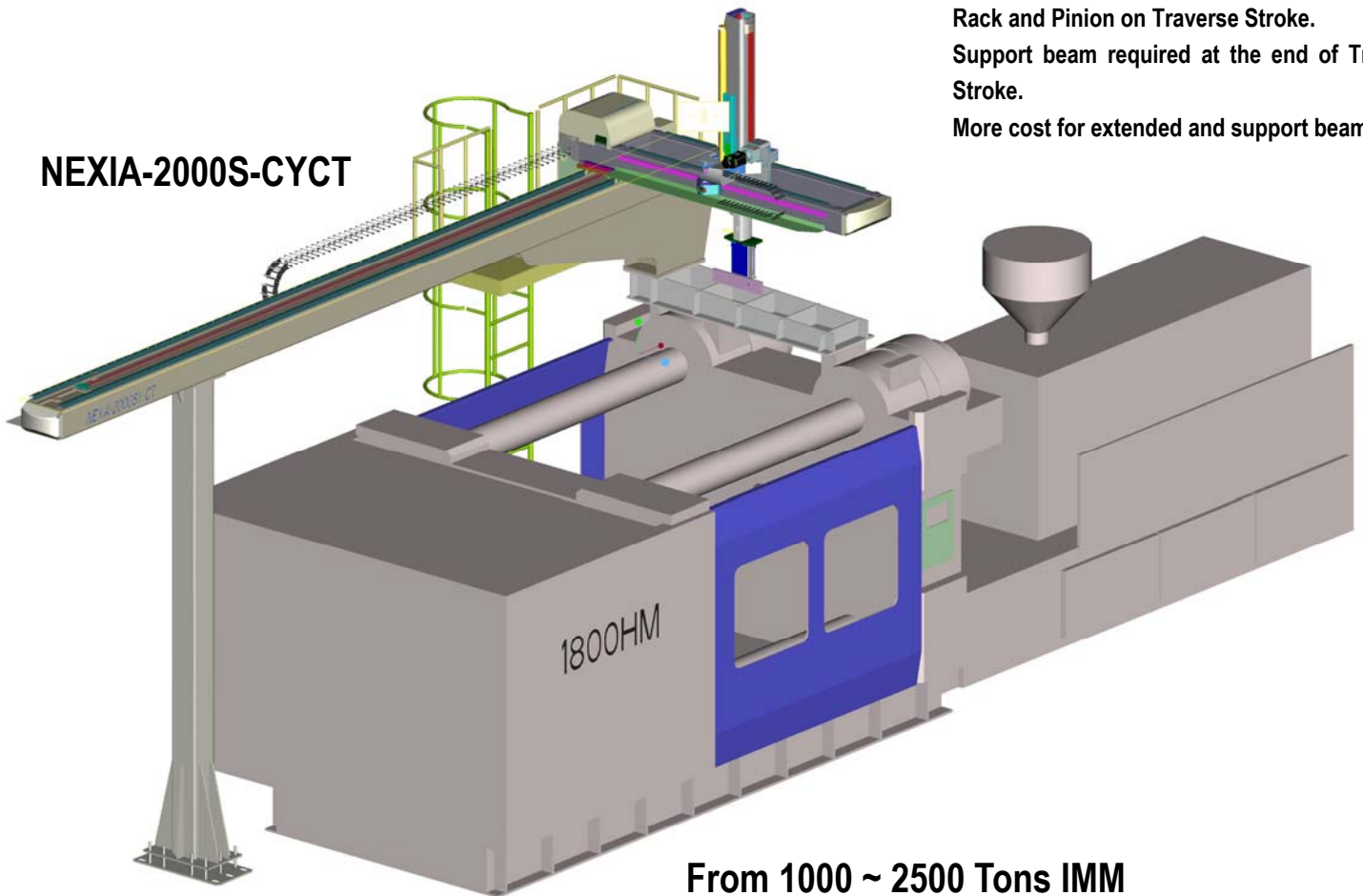

From 1000 ~ 2500 Tons IMM



HYROBOTICS CORP
5988 MID RIVERS MALL DR. ST. LOUIS MO 63304
TEL : 1-636-578-6059, Fax : 1-866-232-5594
WWW.HYROBOTS.COM , Email : Sales@hyrobots.com

All information is subject to change without any notice . All right reserved.